

Parts Book

1 机壳部件 ARM BED COMPONENTS

1、机壳部件 ARM BED COMPONENTS

序号 Ref. No	Description	名 称	数量 Qty	备 注 Memo
1	Arm	机壳	1	
2	Trade mark plate	底板	1	
3	Ruler plate	夹具座	1	
4	Screw	夹具座螺钉	2	
5	Face plate	面板	1	
6	Rear cover (small)	后盖板 (小)	1	

2、上轴、竖轴、针杆挑线部件

2. NEEDLE BAR AND THREAD TAKE-UP. ARM SHAFT AND VERTICAL SHAFT MECHANISM

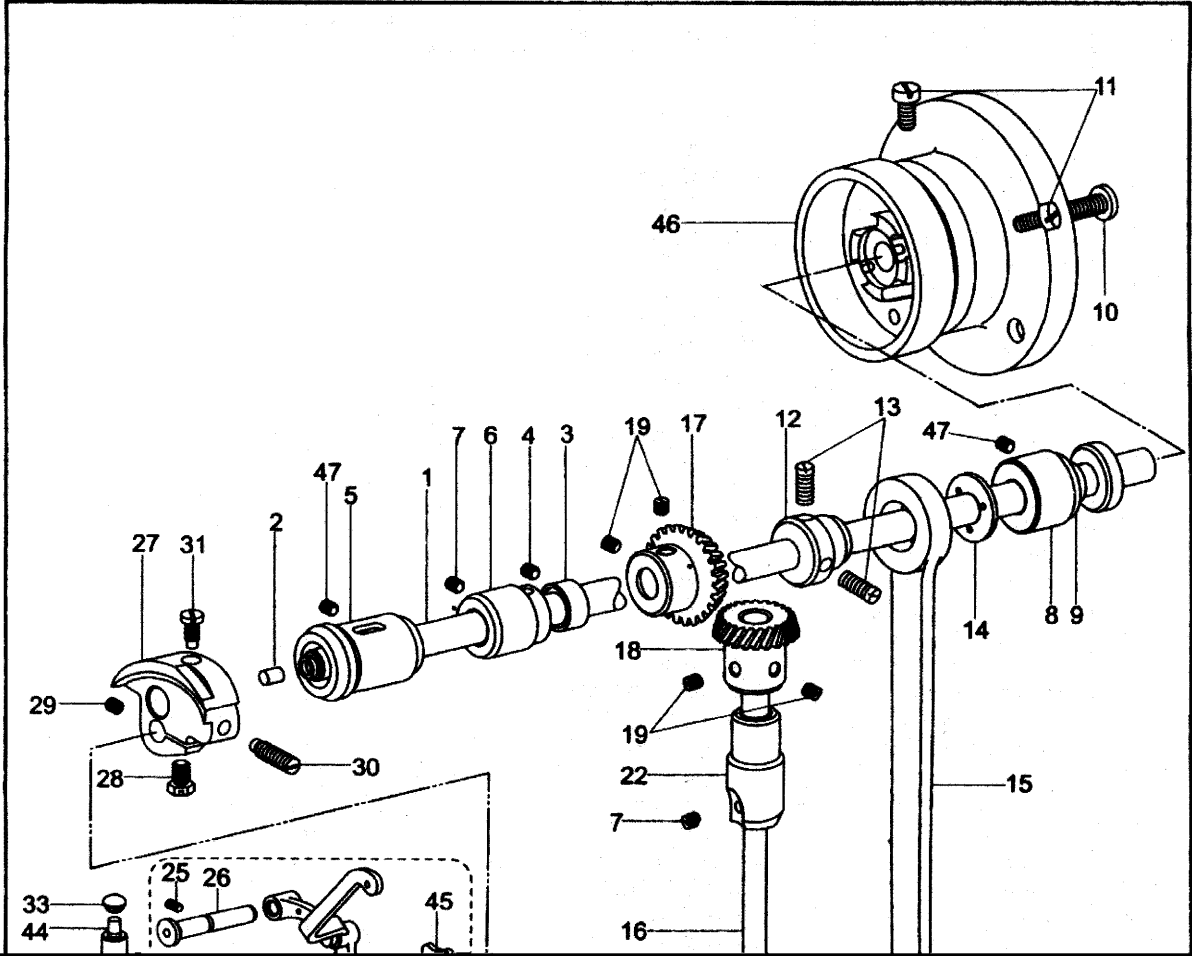

2、上轴、竖轴、针杆挑线部件

2. NEEDLE BAR AND THREAD TAKE-UP, ARM SHAFT AND VERTICAL SHAFT MECHANISM

序号 Ref. No.	Description	名 称	数量 Qty	备 注 Memo
----------------	-------------	-----	--------	----------

3、抬牙送布勾线部件 FEED AND FEED LIFTING AND ROTATING HOOK MECHANISM

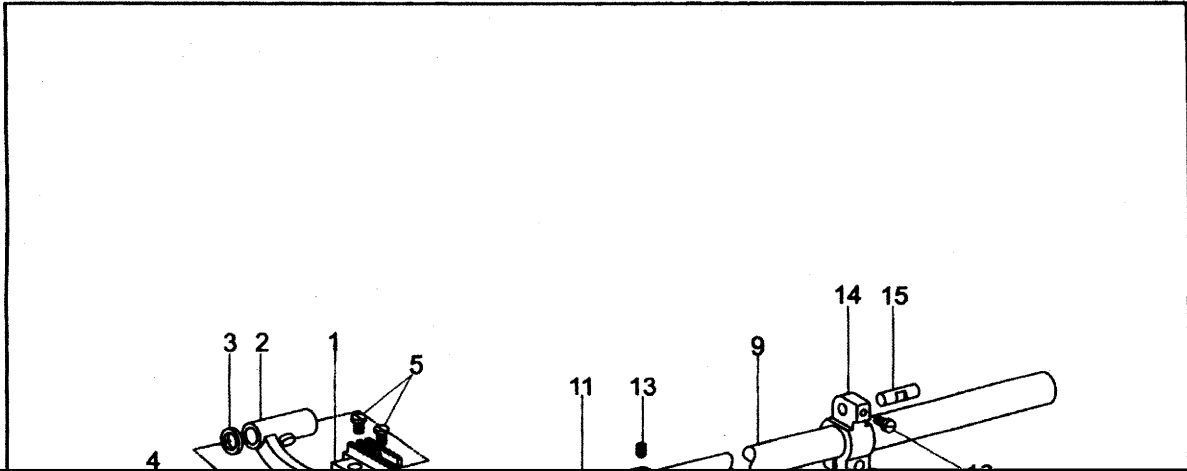

3、抬牙送布勾线部件 FEED AND FEED LIFTING AND ROTATING HOOK MECHANISM

序号 Ref. No	Description	名 称	数量 Qty	备 注 Memo
1	Feed dog	送布牙	1	
2	Feed bar asm	牙架小组件	1	
3	Washer	平垫圈		

4、送布调节部件 STITCH LENGTH REGULATING MECHANISM

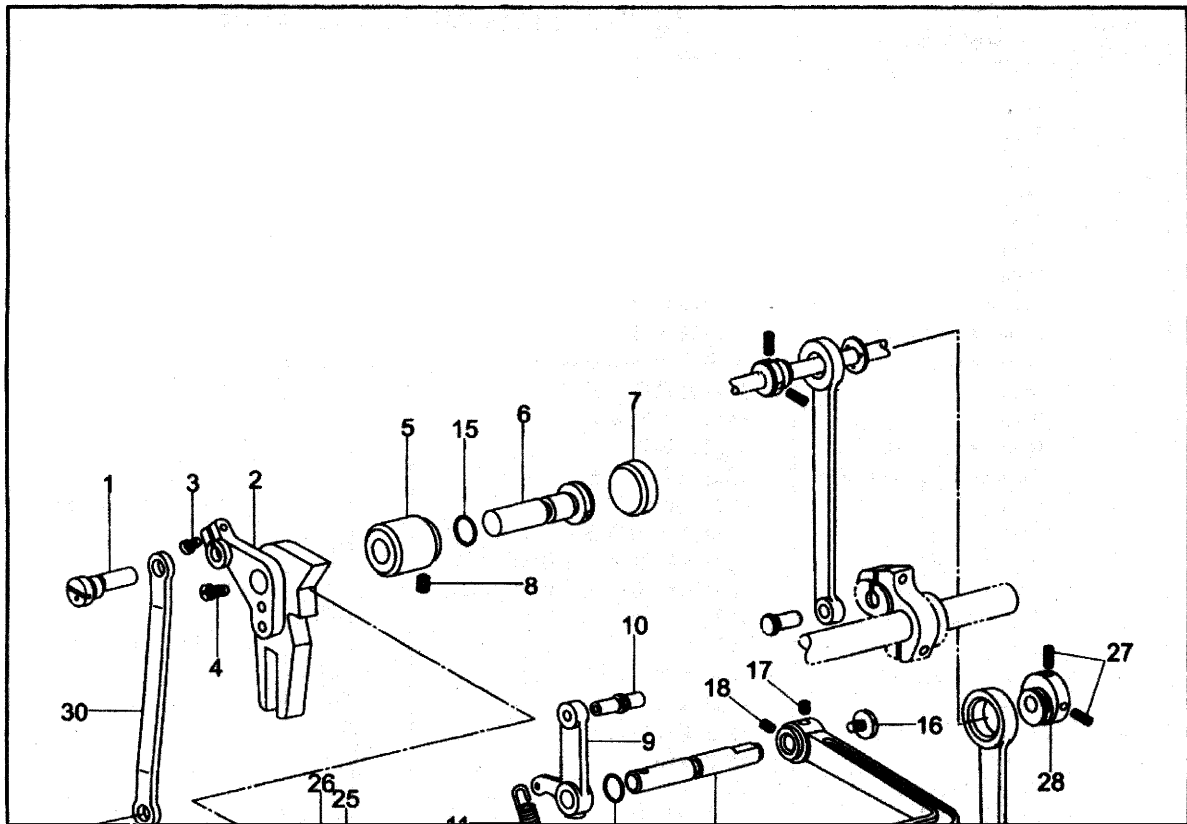

4、送布调节部件 STITCH LENGTH REGULATING MECHANISM

序号 Ref. No	Description	名 称	数量 Qty	备 注 Memo
1	Hinge pin	针距调节连杆销钉	1	
2	Feed regulator	针距座	1	
3	Screw	针距座长螺钉	1	
4	Screw	针距座短螺钉	1	
5	Feed regulator bushing	针距座衬套	1	
6	Hinge pin for regulator	针距座轴	1	
7	Rubber plug	橡皮塞	1	φ20
8	Screw	针距座衬套紧固螺钉	1	
9	Reverse feed crank	倒缝操纵杆曲柄	1	
10	Slide block pin arm	操纵杆曲柄滚柱组件	1	
11	Spring	操纵杆曲柄弹簧	1	
12	Screw	操纵杆曲柄螺钉	1	
13	Reverse feed lever	倒缝操纵杆	1	
14	Reverse feed lever shaft	倒缝操纵杆短轴	1	
15	O Ring	O型密封圈	2	8×1.9 GB1235
16	Screw	倒缝操纵吊紧螺钉	1	
17	Screw	反向送料扳手定位螺钉	1	
18	Screw	反向送料扳手支头螺钉	1	
19	Adjust screw	针距调节螺杆	1	
20	O Ring	O型密封圈	1	14×2.4 GB1235
21	Needle gauge dial	针距盘	1	
22	Mark	针距标盘	1	
23	Washer	标盘螺钉衬套	1	
24	Screw	针距盘螺钉	1	
25	Positioning pin	止动销	1	
26	Spring	止动销弹簧	1	
27	Screw	送布凸轮螺钉	2	
28	Feed drive cam	送布凸轮	1	
29	Level feed connecting rod	送布连杆	1	
30	Feed connecting link	针距调节连杆	1	

5、压脚部件 PRESSER LIFTING MECHANISM

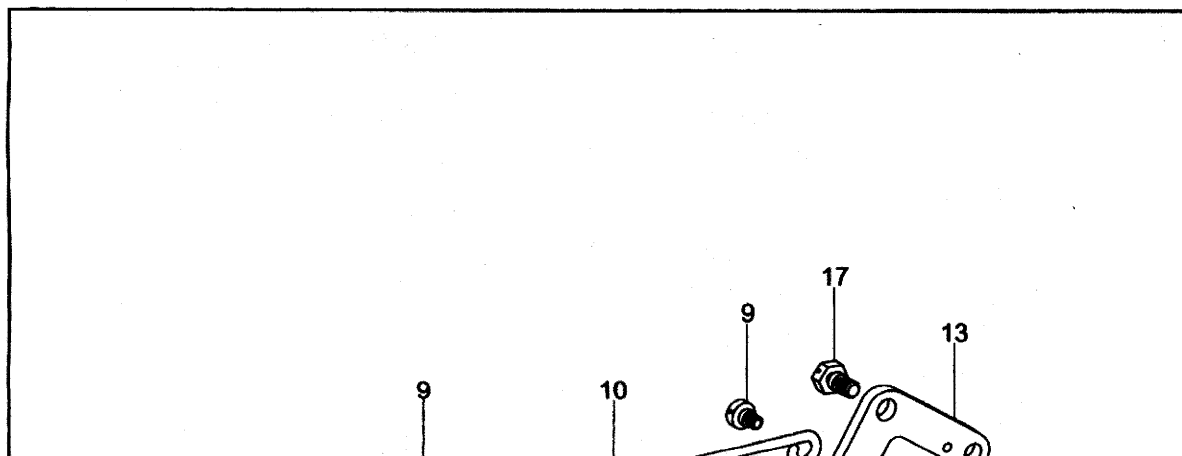

5、压脚部件 PRESSER LIFTING MECHANISM

序号 Ref. No	Description	名 称	数量 Qty	备 注 Memo
1	Presser bar lifter	压脚扳手	1	
2	Screw	压脚扳手螺钉	1	
3	Presser bar lifter cam	压紧杆提升凸轮	1	
4	O Ring	压紧杆提升凸轮油封	1	8×1.9 GB1235
5	Knee lifter lever (Left) asm	膝控提升杠杆（左）组件	1	
6				

6、上送料部件 PRESSER LIFTING FEEDING MECHNISM

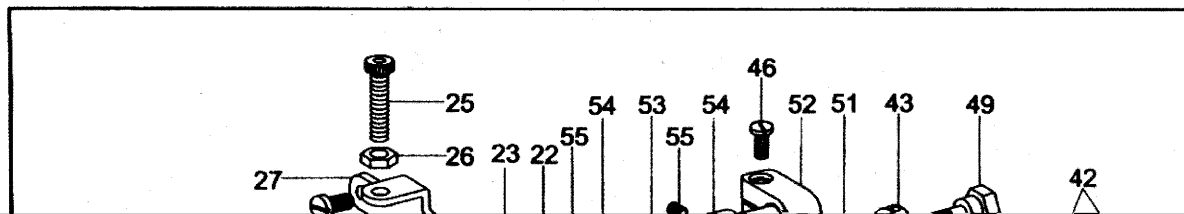

6、上送料部件 PRESSER LIFTING FEEDING MECHNISM

序号 Ref. No	Description	名 称	数量 Qty	备 注 Memo
1	Nut	压脚送料变动连接螺母	1	
2	Shin	压脚连杆压板垫块	2	
3	Nut	压脚曲柄连接螺母	1	
4	Washer	压脚曲柄连接垫圈	1	GB95-85-6
5	Guide shaft	送料曲柄导柱轴	1	
6	Guide pin	提升压脚导柱轴滚柱	1	
7	Out presser foot	摆压脚	1	
8	Screw	压脚螺钉	1	
9	Screw	摆动连杆座螺钉	4	
10	Washer	摆动连杆座螺钉弹簧垫圈	2	GB95-85-4
11	Presser rod guide	摆压脚杆座	1	
12	Presser swing crank link	摆压脚连杆	1	
13	Screw	压脚送料变动连接螺钉	1	
14	Lifting presser sway crank	摆压脚叉型杆	1	
15	Pin	摆压脚叉型杆销	1	
16	Crank shaft complete	压脚送料变动曲柄轴组件	1	
17	Presser swing crank (left)	压脚摆动前曲柄	1	
18	Pin	圆锥销	1	GB117-86 A4X24

7、油泵部件 LUBRICATION MECHANISM

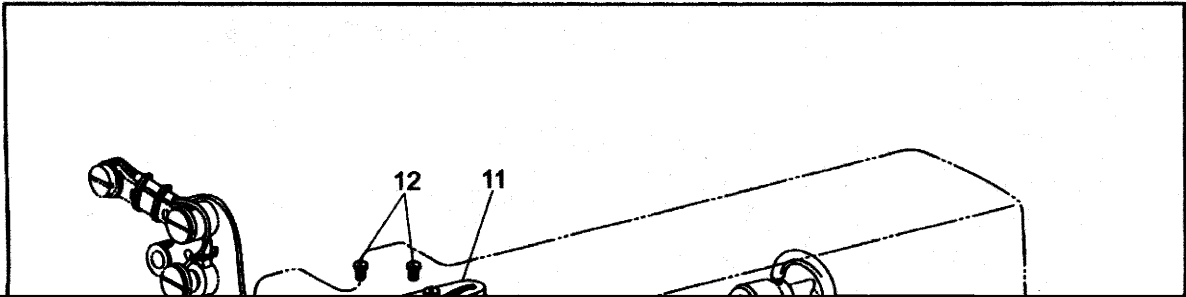

7. 润滑剂 LUBRICATION MECHANISM

8、附件 ACCESSORIES

[Redacted]

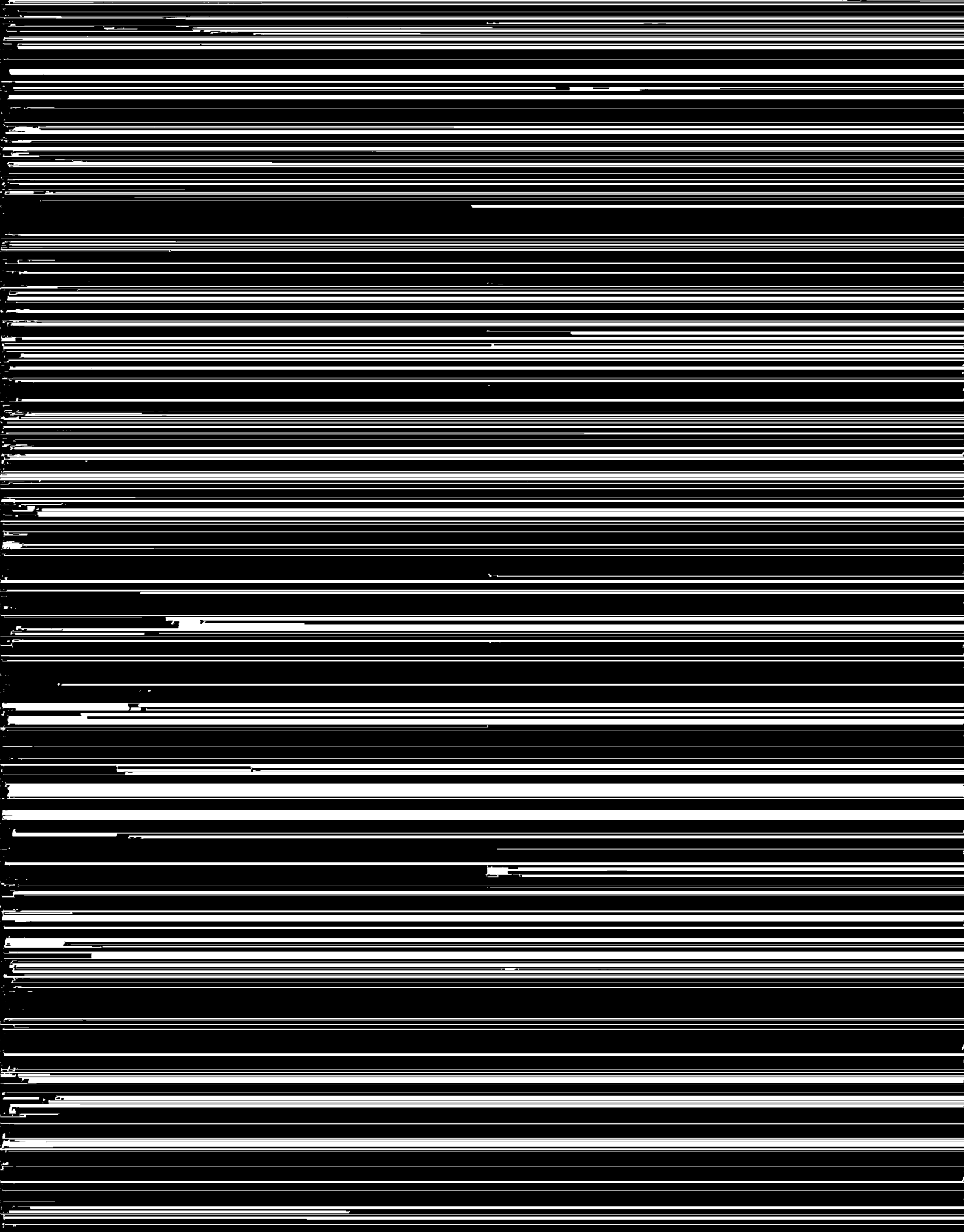

8: 附件 ACCESSORIES

序号 Ref. No	Description	名 称	数量 Qty	备 注 Memo
1	Oil reservoir	油盘	1	
2	Oil drain screw	放油螺钉	1	
3	Washer	放油螺钉垫圈	1	
4	Gasket for oil reservoir (Small)	油盘垫 (小)	1	
5	Gasket for oil reservoir (Big)	油盘垫 (大)	1	
6	Hinge pin for knee lifter	膝控铰链轴	1	
7	Back spring for knee lifter	膝控复位弹簧	1	
8	Knee lifter stop bracket	膝控限位架	1	
9	Adjusting screw	膝控限位调节螺钉	2	
10	Lock nut	调节螺母	2	
11	Screw	膝控限位架螺钉	1	
12	Knee lifter lifting rod	膝控提升顶杆	1	
13	Joint knee lifer bell crank	碰块弯杆接头	1	
14	Screw	碰块弯杆接头螺钉	2	
15	Knee lifter bell crank	膝控碰块弯杆	1	
16	Knee lifter plate	膝控碰块	1	
17	Bracket for knee lifter plate	碰块架	1	
18	Screw	碰块架螺钉	1	
19	Pad for knee lifter plate	碰块垫	1	
20	Retaining ring	开口挡圈	1	GB896-76
21	Belt cover case asm	皮带罩组件	1	
22	Screw (Small)	皮带罩螺钉 (小)	2	M4×8 GB67-85
23	Washer	皮带罩螺钉垫圈	2	GB848-85-4
24	Screw (big)	皮带罩螺钉 (大)	2	M5×12GB67-85
25	Bobbin winder asm	绕线器组件	1	
26	Thread stand asm	线架组件	1	
27	Oil contaier	油箱	1	